



PZB
Hydraulic Energy

42591

#PTO per cambi KAMAZ

POSSIBLE SOLUTIONS

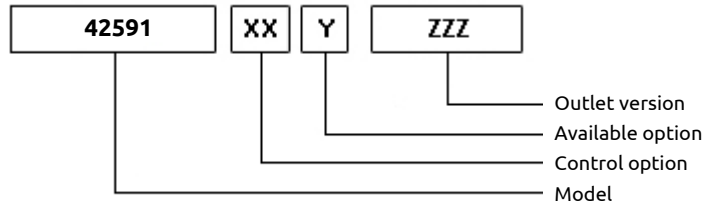
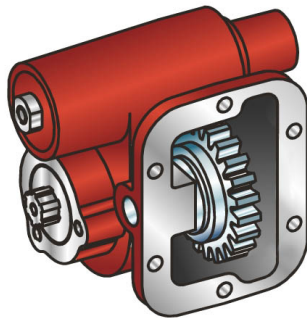

05/09/2014

TEC. SPECIFICATIONS

Status	In production	Revision	0
Torque (NM)	320	Replaces	
Int. Ratio	1,83	Replaced by	
Teeth number	22		

CONTROL TYPE PZB

- | | | |
|--|---|---|
| <input type="checkbox"/> Mechanical with lever remote control (TC) | <input type="checkbox"/> Hydraulic control | <input checked="" type="checkbox"/> Pneumatic |
| <input type="checkbox"/> Ready for electric solenoid control | <input type="checkbox"/> Depressure control | <input type="checkbox"/> Constantly engaged |
| <input type="checkbox"/> Mechanical with PUSH-PULL remote control | <input type="checkbox"/> Electric control KES 5 | <input type="checkbox"/> Ready for detached control |

CONTROL VERSIONS (XX)

Type	82z1	Description
1 (Pneumatic)	1	#Comando Standard M12x1.25

AVAILABLE OPTIONS (Y)

82z1	Description	Lubr. Kit	Switch Kit	Reinforced
0	#Non presente			<input type="checkbox"/>
1	#Tappo ispezione			<input type="checkbox"/>
2	#Con Coper. di Protezione			<input type="checkbox"/>

OUTLET VERSIONS (ZZZ)

82z1	Description
FC2	Special flange dia.118 g.boxes MAZ - KAMAZ
FD2	Special flange dia.118 g.boxes MAZ - KAMAZ
P41	3-HOLE PUMP FRONT UNI (SIDE A)
P42	3-HOLE PUMP REAR UNI (SIDE B)
PR2	3-HOLE PUMP REAR UNI/R (SIDE B)



PZB[®]
Hydraulic Energy

42591

#PTO per cambi KAMAZ

Conversion kit

Flange kit

82z1

Description

205F5960000	SPICER 1120 FOR M8
205F5970000	SPICER 1300 FOR M8
205F5980000	DIN 10 FOR M8
205F5990000	DIN 00 FOR M8

Lubrication kit

Switch kit

Bracket kit

ELECTRIC KITS



PZB
Hydraulic Energy

42591

#PTO per cambi KAMAZ

TECH.PICTURE

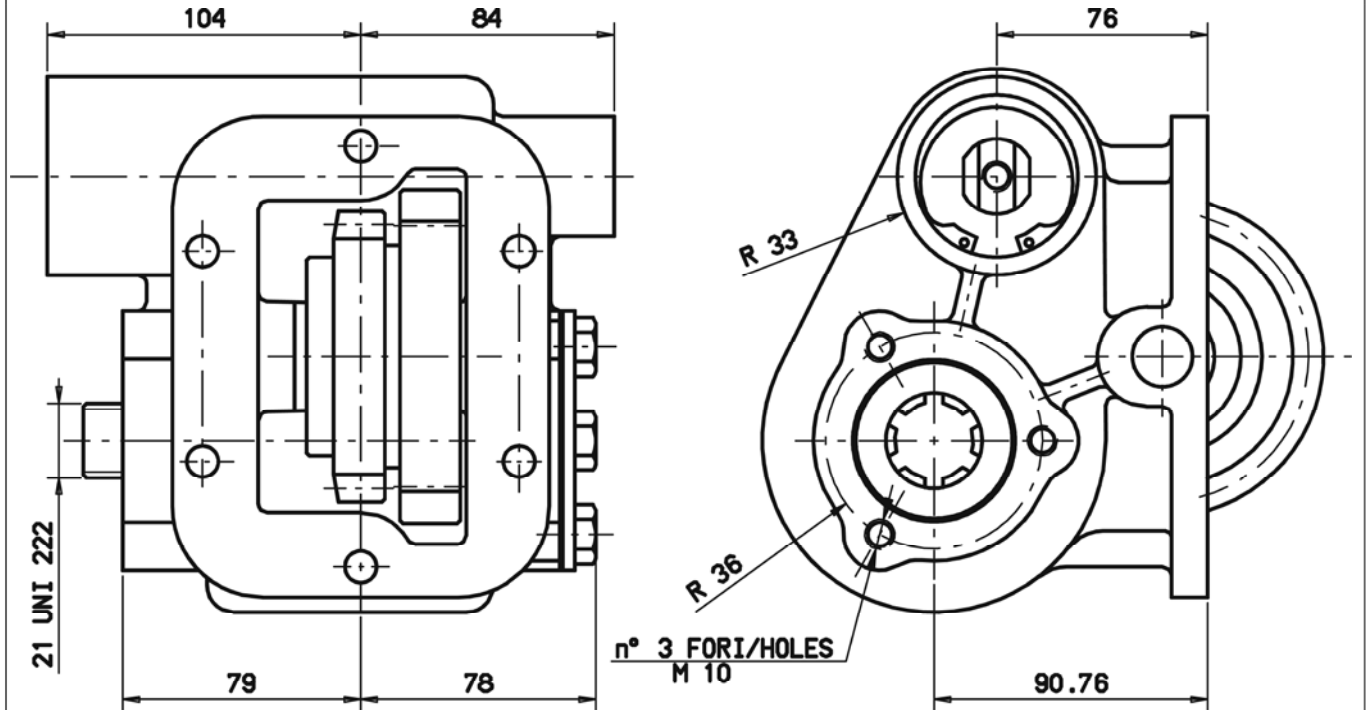



PZB
Hydraulic Energy

42591

#PTO per cambi KAMAZ

EXPLODED VIEW

